

Installation guide

IQ3.0

SALTO
inspiredaccess

- Eng Installation guide
- E Guía de instalación
- D Montageanleitung
- F Guide d'installation
- P Guia de instalação

The IQ3 is a Gateway device that ensures the communication between Nebula and the SALTO BLUEnet devices providing the SVN (SALTO Virtual Network) features.

It is equipped with an Ethernet, WIFI (*), Bluetooth and RS-485 interface.

(*) Depending on the model.

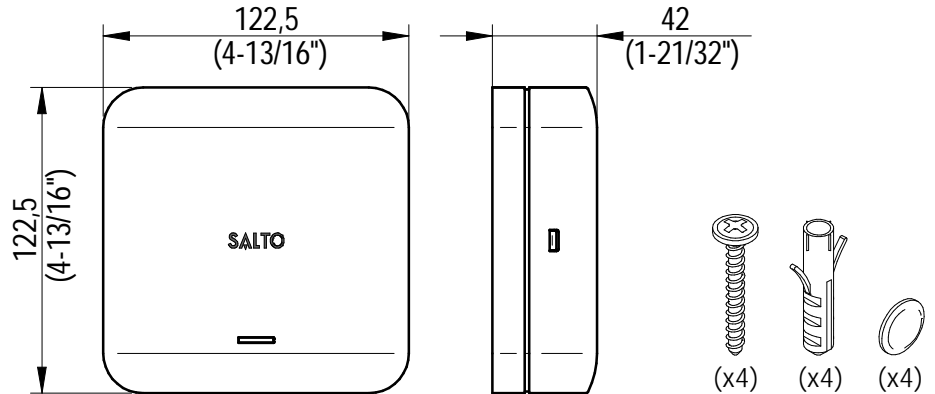

Eng Installation E Instalación D Installation F Installation P Instalação

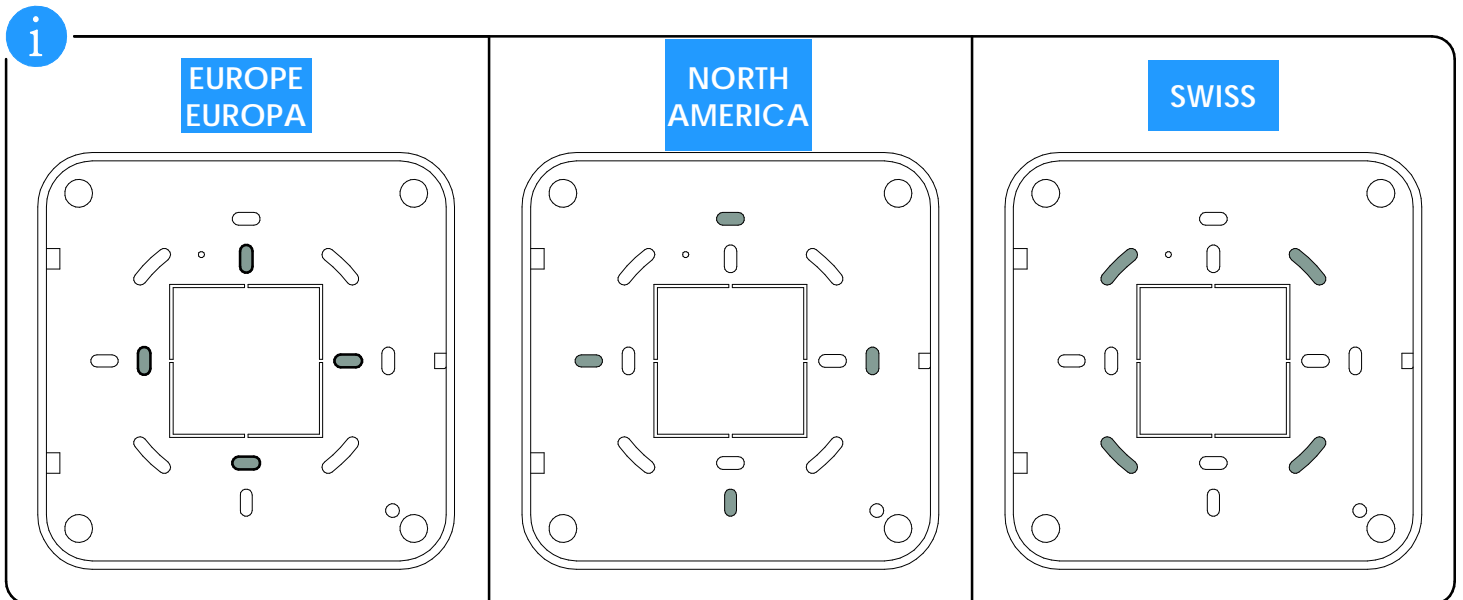

Eng CEILING/WALL INSTALLATION WITH HIDDEN CABLE E INSTALACIÓN EN TECHO/PARED CON CABLE OCULTO D DECKEN-/WANDMONTAGE MIT UNTERPUTZ VERKABELUNG F INSTALLATION AU PLAFOND / MUR AVEC CÂBLE CACHÉ P INSTALAÇÃO NO TETO / PAREDE COM CABO OCULTO

PZ2

1

- Eng Remove!
- E ¡Retirar!
- D Entfernen!
- F Enlever!
- P Remover!

2

- Eng SEE WIRING DIAGRAM
- E VER CONEXIONADO
- D SIEHE VERKABELUNGSPLAN
- F VOIR SCHÉMA DE CÂBLAGE
- P VER DIAGRAMA DE CABLAGEM

Installation guide

IQ3.0

SALTO
inspiredaccess

Eng CEILING/WALL INSTALLATION WITH EXPOSED CABLE
D DECKEN-/WANDMONTAGE MIT AUFPUTZ VERKABELUNG
P INSTALAÇÃO NO TETO/PAREDE COM CABO EXPOSTO

E INSTALACIÓN EN TECHO/PARED CON CABLE VISTO
F INSTALLATION AU PLAFOND / MUR AVEC CÂBLE EXPOSÉ

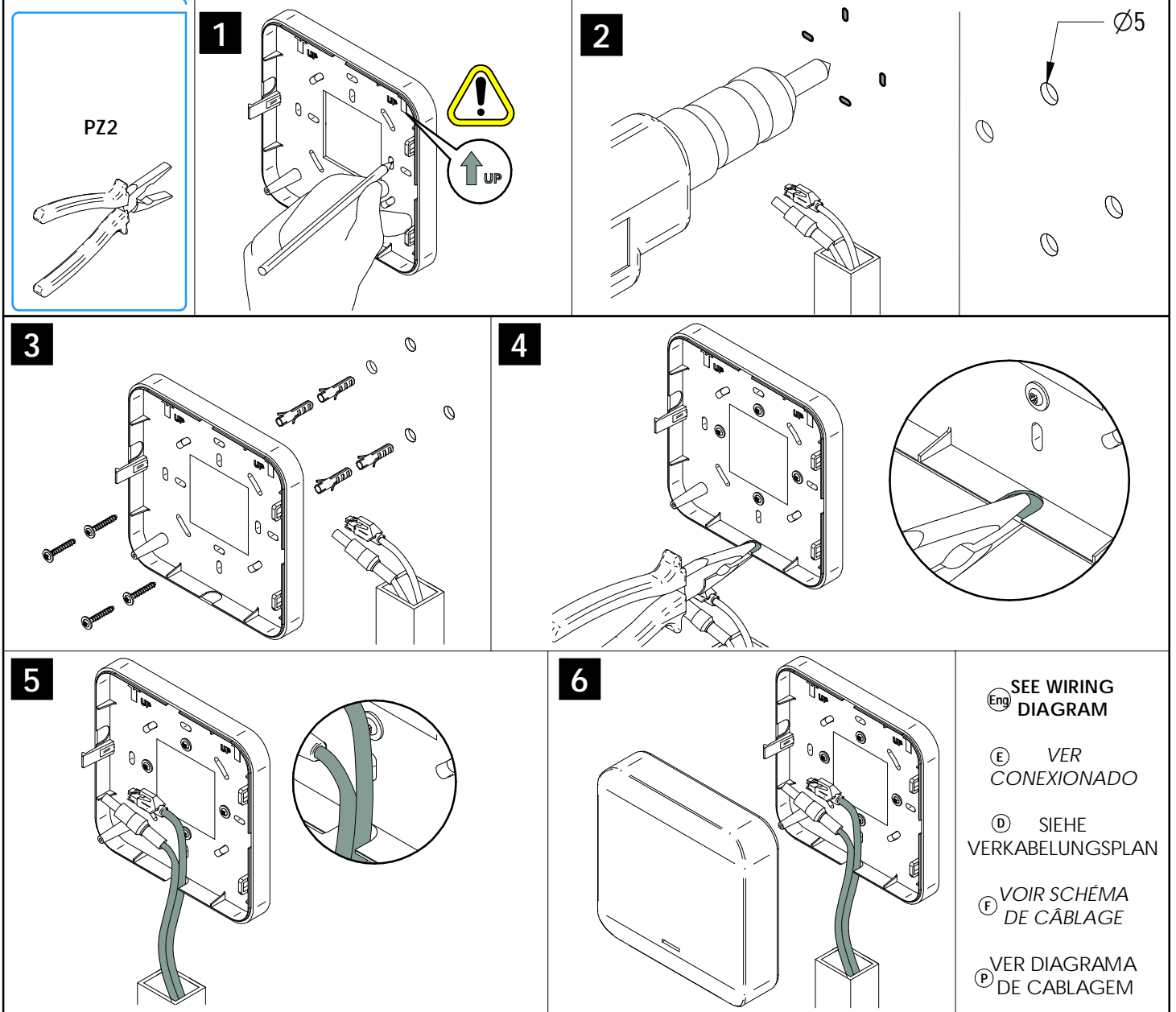

Eng DESKTOP INSTALLATION
E INSTALACIÓN SOBREMESA
D TISCHMONTAGE
F INSTALLATION DE BUREAU
P INSTALAÇÃO DE SECRETÁRIA

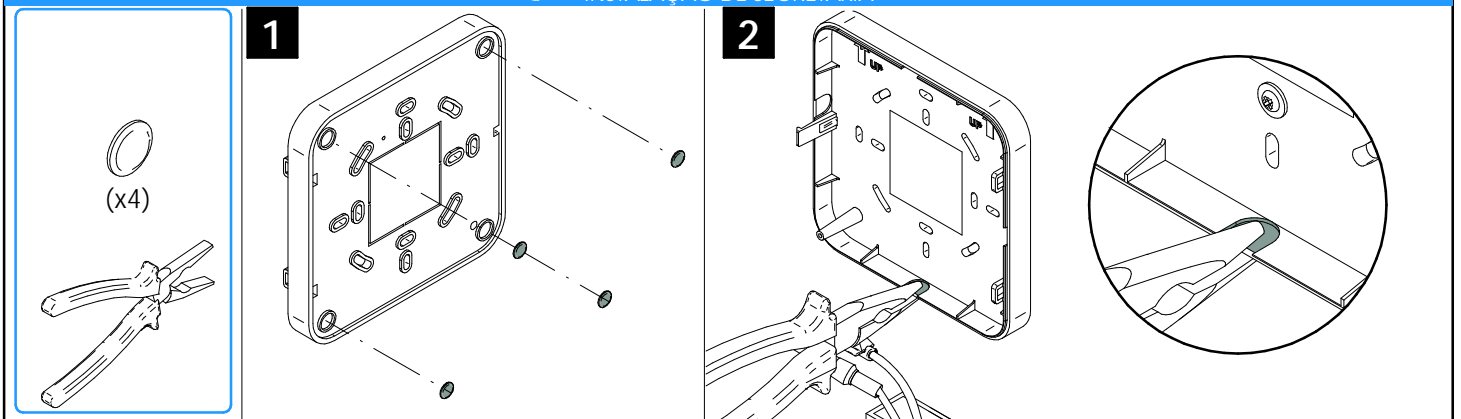

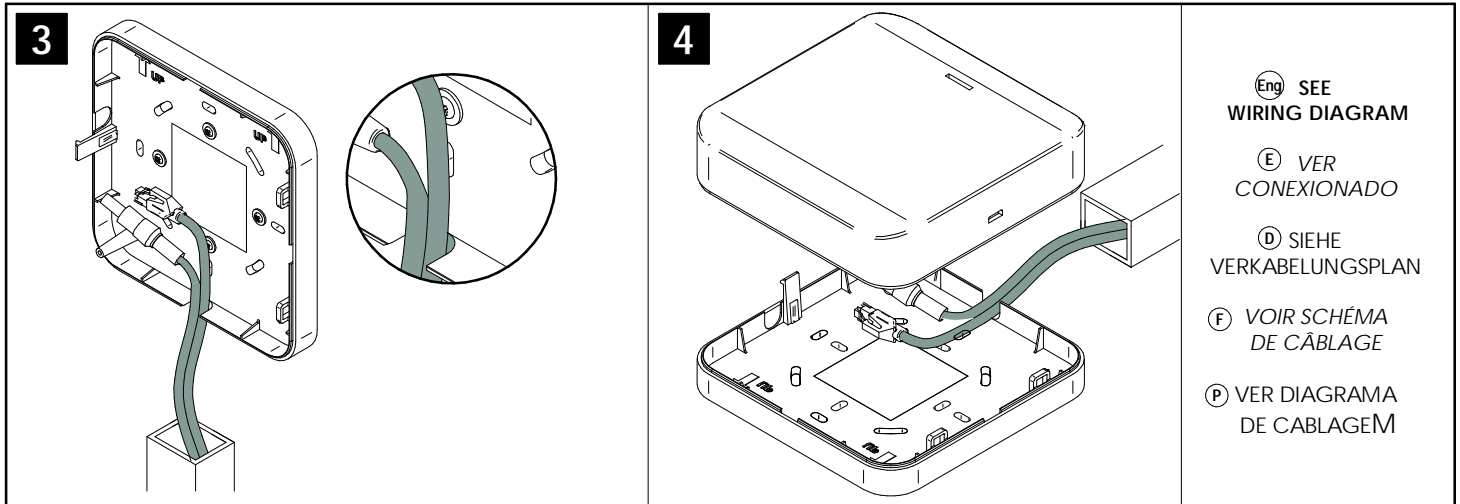

- Eng SEE WIRING DIAGRAM
- E VER CONEXIONADO
- D SIEHE VERKABELUNGSPLAN
- F VOIR SCHÉMA DE CÂBLAGE
- P VER DIAGRAMA DE CABLAGEM

Eng Wiring E Conexionado D Verkabelung F Câblage P Cablagem

- a Eng ETHERNET MODEL
E P MODELO ETHERNET
F MODÈLE ETHERNET

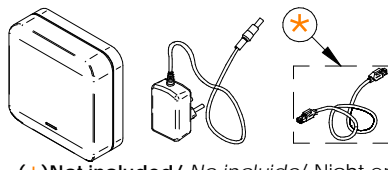

(*Not included/ No incluido/ Nicht enthalten/ Non inclus/ Não incluso)

- b Eng ETHERNET + POE MODEL
E P MODELO ETHERNET + POE
F MODÈLE ETHERNET + POE

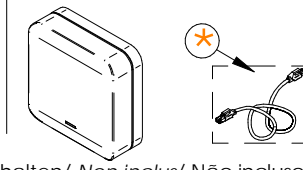

- c Eng ETHERNET + WIFI MODEL
E P MODELO ETHERNET + POE
F MODÈLE ETHERNET + POE

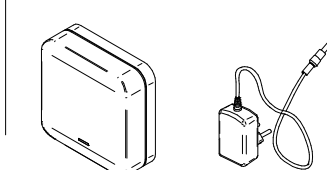

a ETHERNET MODEL

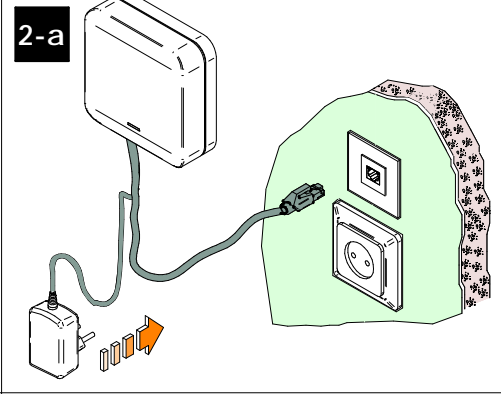
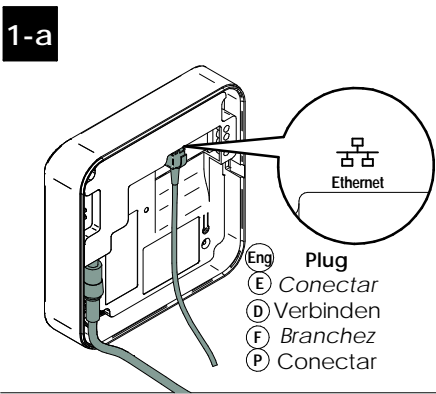

b ETHERNET + POE MODEL

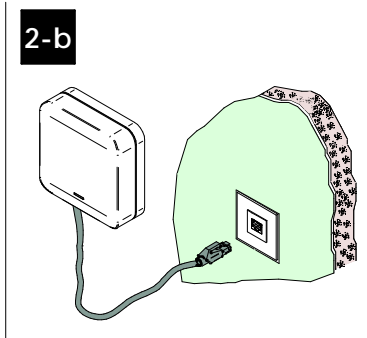
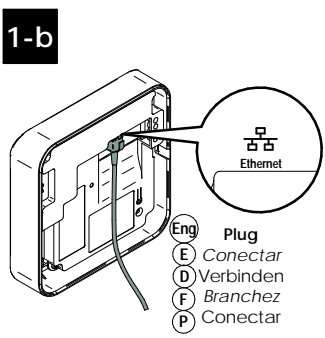

Eng If there is no PoE infrastructure, use auxiliary power supply.
E En caso de que no haya infraestructura PoE, utilizar alimentación auxiliar.
D Wenn keine PoE-Infrastruktur vorhanden ist, verwenden Sie eine externe Stromversorgung.
F En cas d'absence d'infrastructure PoE, utiliser une alimentation électrique auxiliaire.
P Se não houver uma infraestrutura PoE, utilize uma fonte de alimentação auxiliar.

1

Eng Plug
E Conectar
D Verbinden
F Branchez
P Conectar

2

Installation guide

IQ3.0

SALTO
inspiredaccess

a ETHERNET + WIFI MODEL

1-a

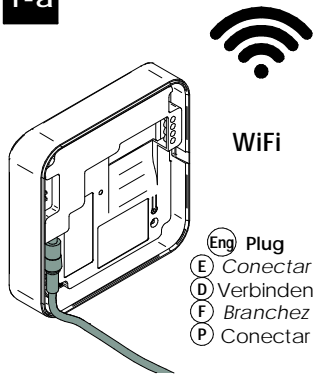

2-a

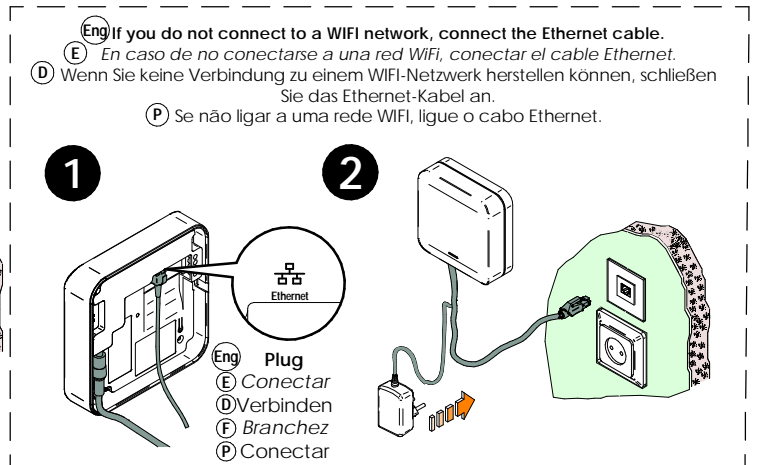
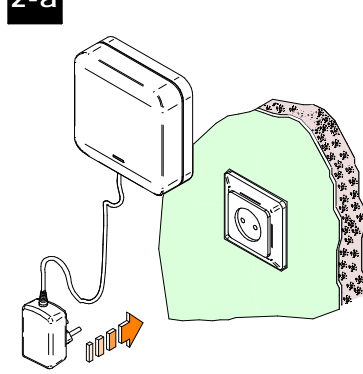

- (Eng) COMMUNICATION WIRING DIAGRAM IN IQ3/SALTO Node
 (E) CONEXIONADO COMUNICACIONES EN IQ3 / SALTO Node
 (D) ANSCHLUSSPLAN des IW3/Salto
 (F) SCHÉMA DE CÂVLAGE DE LA COMMUNICATION DANS LE NOEUD DE IQ3/Salto
 (P) DIAGRAMA DOS FIOS DE COMUNICAÇÃO ENTRE IQ37/NODE SALTO

- (Eng) RS485 CONNECTION TO TERMINAL.
 (E) CONEXIÓN RS485 A BORNA.
 (D) RS485 ANSCHLUSS AM TERMINAL.
 (F) BRANCHEMENT RS485 AU TERMINAL.
 (P) LIGAÇÃO RS485 AOS TERMINAIS.

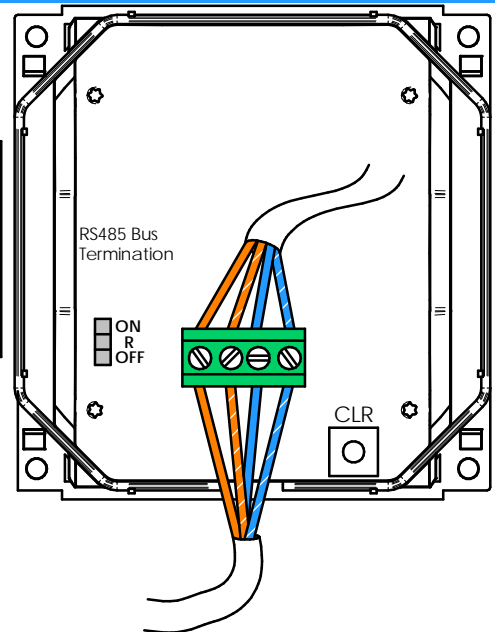
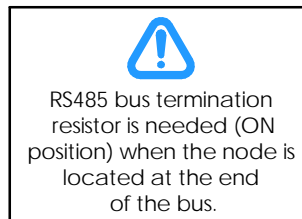
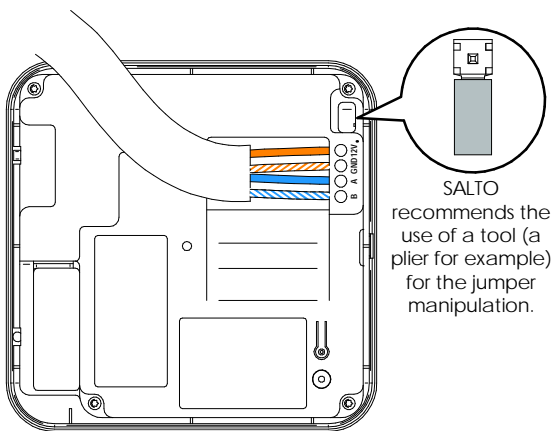

- (Eng) RS485 CONNECTION WITH CABLE JACK
 (E) CONEXIÓN CRS485 CON CABLE JACK
 (D) RS485 VERBINDUNG MIT STECKERN
 (F) BRANCHEMENT RS485 AVEC CÂBLE JACK
 (P) LIGAÇÃO RS485 POR CABO BOM FICHA RJ45

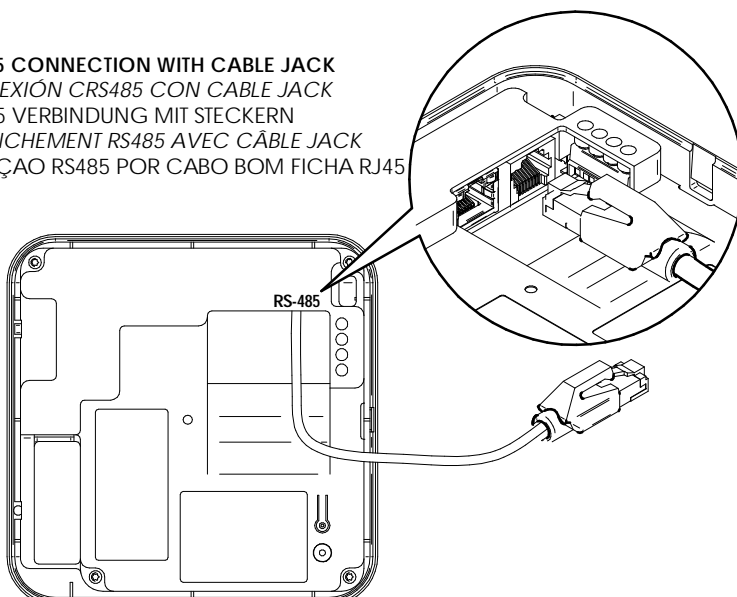

- Only with SP226159 (Eng)
 Solo con SP226159 (E)
 Nur mit SP226159 (D)
 Uniquement avec SP226159 (F)
 Apenas com SP226159 (P)

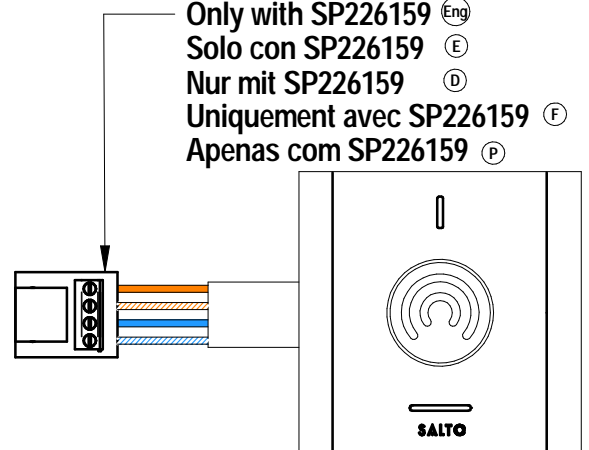

Installation guide

IQ3.0

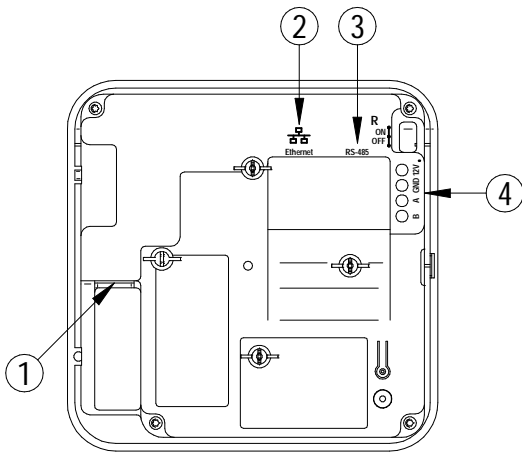

- Eng
- ① Power (except PoE).
 - ② Ethernet.
 - ③ RS485 (Jack cable).
 - ④ RS485.

- F
- ① Alimentation (sauf PoE).
 - ② Ethernet.
 - ③ RS485 (câble Jack).
 - ④ RS485.

- E
- ① Alimentación (excepto PoE).
 - ② Ethernet.
 - ③ RS485 (cable Jack).
 - ④ RS485.

- P
- ① Fonte de alimentação (excepto PoE).
 - ② Ethernet.
 - ③ RS485 (Cabo com ficha RJ45).
 - ④ RS485.

- D
- ① Stromversorgung (exkl PoE).
 - ② Ethernet.
 - ③ RS485 (Anschlussbuchse).
 - ④ RS485.

Eng Electrical Features E Características Eléctricas D Elektronische Charakteristik F Caractéristiques Électriques P Catacterísticas Eléctricas

EXTERNAL POWER SUPPLY CHARACTERISTICS			
	Min	Max	Typ
Input Voltage	12-5%V	12+5%V	12V
Max Input Power	15w		
Current Consumption*		200mA	60mA

* Excluding RS485 Nodes.
Power supply must be calculated taking into account SALTO Nodes current consumption.

WIFI CHARACTERISTICS	
Frequency Range	2400 MHz to 2483.5 MHz
Standard	IEEE 802.11b/g/n compliant
TX power	16dBm
Range	25 - 30m *

* Depending upon installed environment. To ensure correct operation, do not install the device near a metallic surface.

CABLE REQUIREMENTS	
Ethernet	UTP CAT5e
Node Connection	By means of Terminal Blocks: Generic twisted pair By means of RJ45: UTPCAT5e

MAX. NUMBER OF DEVICES TO BE CONNECTED	
SALTO Nodes	6
Access points	112

OPERATING CONDITIONS		
	Min	Max
Temperature	0°C	60°C
Humidity	0	95% (Non condensing)

PoE	
PoE Norms:	IEEE 802.3af / IEEE 802.3at
PoE Class	0

SALTO BLUeNet CHARACTERISTICS	
Frequency Range	2400 MHz to 2483.5 MHz
Standard	Bluetooth 5.2 Compliant
TX power	8dBm
Indoor Range	10 - 15m *

* The environment has a direct impact on the BLUeNet range radiation (metal, concrete walls...)
The receiver device must be located facing the product antenna. Please check your product's BLUeNet antenna position.
Recommended connectivity distance: 10m - 15m

CARACTERÍSTICAS DE LA FUENTE DE ALIMENTACIÓN EXTERNA			
	Min	Max	Typ
Tensión de entrada	12-5%V	12+5%V	12V
Potencia max de entrada	15w		
Consumo de corriente*		200mA	60mA

* Excepto RS485 Nodes.
La alimentación eléctrica debe de ser calculada teniendo en cuenta el consumo de corriente del conjunto de Nodos SALTO.

CARACTERÍSTICAS WIFI	
Rango de frecuencia	2400 MHz to 2483.5 MHz
Norma	IEEE 802.11b/g/n compliant
Potencia TX	16dBm
Alcance	25 - 30m *

* Dependiendo del entorno en el que va a ser instalado.
Para asegurar el correcto funcionamiento, no instalar el dispositivo cerca de una superficie metálica.

REQUISITOS DE CABLE	
Ethernet	UTP CAT5e
Conexión de Node	Bloque de terminal : Pares trenzados RJ45: UTPCAT5e

NUMERO MAX. DE DISPOSITIVOS CONECTADOS	
Nodos SALTO	6
Puntos de acceso	112

CONDICIONES DE FUNCIONAMIENTO		
	Min	Max
Temperatura	0°C	60°C
Humedad	0	95% (Sin condensación)

PoE	
Norma PoE:	IEEE 802.3af / IEEE 802.3at
Clase de PoE	0

Installation guide

IQ3.0

CARACTERÍSTICAS DE SALTO BLUENet	
Rango de frecuencia	2400 MHz to 2483.5 MHz
Norma	Bluetooth 5.2 Compliant
Potencia TX	8dBm
Alcance en interiores	10 - 15m *

* El entorno tiene un impacto directo sobre el rango de radiación de BLUENet (metal, paredes de hormigón...)
El dispositivo receptor debe ubicarse frente a la antena del producto. Compruebe la posición de la antena BLUENet de su dispositivo.
Distancia de conectividad recomendada: 10m - 15m

Ⓓ

EXTERNE SPANNUNGSVERSORGUNG			
	Min	Max	Typ
Eingangsspannung	12-5%V	12+5%V	12V
Max. Leistungsaufnahme	15w		
Stromverbrauch*	200mA	60mA	

* Ohne RS485 Nodes.

Die Stromversorgung muss unter Berücksichtigung der Stromaufnahme der SALTO Nodes berechnet werden.

VERKABELUNG	
Ethernet	UTP CAT5e
Node verbindung	Mittels klemmenblöcken: generisches twisted pair Mittels RJ45: UTPCAT5e

UMGEBUNGSBEDINGUNGEN		
	Min	Max
Temperatur	0°C	60°C
Luftfeuchtigkeit	0	95% (Nicht kondensierend)

SALTO BLUENet CHARAKTERISTIK	
Frequenzbereich	2400 MHz to 2483.5 MHz
Standard	Bluetooth 5.2 Compliant
TX stärke	8dBm
Reichweite drinnen	10 - 15m *

*Die Umgebung hat einen direkten Einfluss auf die Reichweite der BLUENet Funkvernetzung (z.B. Metall, Betonwände etc.)
Das Empfangsgerät muss in Richtung der Produktantenne ausgerichtet sein. Bitte überprüfen Sie die Position der BLUENet Antenne Ihres Produkts. Empfohlener Abstand: 10 bis 15 Meter.

WIFI CHARAKTERISTIK	
Frequenzbereich	2400 MHz to 2483.5 MHz
Standard	IEEE 802.11b/g/n compliant
TX stärke	16dBm
Reichweite	25 - 30m *

* Um einen einwandfreien Betrieb zu gewährleisten, installieren Sie das Gerät dann nicht in der Nähe von einer metallischen Oberfläche.

MAX. ANZAHL DER ANZUSCHLIESSEN DEN GERÄTE	
SALTO Nodes	6
Access points	112

PoE	
PoE Norms:	IEEE 802.3af / IEEE 802.3at
PoE Class	0

Ⓕ

CARACTÉRISTIQUES DE L'ALIMENTATION EXTERNE			
	Min	Max	Typ
Tension d'entrée	12-5%V	12+5%V	12V
Alimentation d'entrée max.	15w		
Consommation de courant*	200mA	60mA	

* À l'exclusion des RS485 Nodes.

L'alimentation doit être calculée en tenant compte de la consommation de courant des Nodes SALTO.

EXIGENCES EN MATIÈRE DE CÂBLES	
Ethernet	UTP CAT5e
Branchement nœud	Au moyen de borniers: paire torsadée générique Au moyen de RJ45: UTPCAT5e

CONDITIONS DE FONCTIONNEMENT		
	Min	Max
Température	0°C	60°C
Humidité	0	95% (Sans condensation)

CARACTÉRISTIQUES DU WIFI	
Plage de fréquences	2400 MHz to 2483.5 MHz
Standard	IEEE 802.11b/g/n compliant
Alimentation TX	16dBm
Range	25 - 30m *

* Selon l'environnement d'installation. Pour garantir un fonctionnement correct, n'installez pas l'appareil à proximité d'une surface métallique.

NOMBRE MAX. D'APPAREILS À BRANCHER	
Nœuds SALTO	6
Points d'accès	112

PoE	
Normes PoE:	IEEE 802.3af / IEEE 802.3at
Classe PoE	0

Installation guide

IQ3.0

CARACTERÍSTICAS SALTO BLUEnet	
Plage de fréquences	2400 MHz to 2483.5 MHz
Standard	Bluetooth 5.2 Compliant
Alimentation TX	8dBm
Plage intérieure	10 - 15m *

* L'environnement a un impact direct sur le rayonnement de la gamme BLUEnet (métal, murs en béton ...)

Le dispositif récepteur doit être placé face à l'antenne du produit. Veuillez vérifier la position de l'antenne BLUEnet du produit. Distance de connectivité maximale : 10m – 15m

(P)

CARACTERÍSTICAS DA FONTE DE ALIMENTAÇÃO EXTERNA			
	Min	Max	Typ
Tensão de entrada	12-5%V	12+5%V	12V
Potência Max. de entrada	15w		
Consumo de corrente*		200mA	60mA

* Ohne RS485 Nodes.

Die Stromversorgung muss unter Berücksichtigung der Stromaufnahme der SALTO Nodes berechnet werden.

CARACTERÍSTICAS WIFI	
Gama de frequência	2400 MHz to 2483.5 MHz
Norma	IEEE 802.11b/g/n compliant
Potência TX	16dBm
Alcance	25 - 30m *

* Um einen einwandfreien Betrieb zu gewährleisten, installieren Sie das Gerät dann nicht in der Nähe von einer metallischen Oberfläche.

REQUISITOS DE CABO	
Ethernet	UTP CAT5e
Ligação do Node	Bloco de terminais: Pares traçados Ficha RJ45: UTPCAT5e

NÚMERO MAX. DE DISPOSITIVOS LIGADOS	
Nodes Salto	6
Puntos de acceso	112

CONDIÇÕES DE OPERAÇÃO		
	Min	Max
Temperatura	0°C	60°C
Humidade	0	95% (Sem condensação)

PoE	
PoE Norms:	IEEE 802.3af / IEEE 802.3at
PoE Class	0

CARACTERÍSTICAS SALTO BLUEnet	
Gama de frequência	2400 MHz to 2483.5 MHz
Norma	Bluetooth 5.2 Compliant
TX power	8dBm
Alcance	10 - 15m *

*O ambiente tem um impacto direto na radiação da gama BLUEnet (metal, paredes de betão...)

O dispositivo recetor deve ser colocado de frente para a antena do produto. Por favor, verifique a posição da antena BLUEnet do seu produto. Distância de conectividade recomendada: 10m – 15m

Eng Configuration **E** Configuración **D** Konfiguration **F** Configuration **P** Configuração

- Eng** 1. The device is configured using the Nebula App.
2. Ethernet test: without any type of set up, the IQ3 is a DHCP ready device. If your network supports it, it is possible to check the Ethernet connectivity by pinging the address SALTO-IQ3-XXXXXX(XXXXXX corresponds to the final 6 digits of MAC).
- E** 1. El dispositivo se configura mediante Nebula App.
2. Ethernet Test: sin haber realizado ninguna configuración, el IQ3 es un dispositivo DHCP ready. Si su red lo soporta, es posible comprobar la conectividad Ethernet mediante ping a la dirección SALTO-IQ3-XXXXXX (XXXXXX se corresponde con los 6 dígitos finales de la MAC).
- F** 1. Das Gerät wird mit der Nebula App konfiguriert.
2. Ethernet Test: Ohne jegliche Art von Einrichtung ist das IQ3 ein DHCP-fähiges Gerät. Wenn Ihr Netzwerk dies unterstützt, ist es möglich, die Ethernet-konnektivität zu überprüfen, indem Sie die Adresse SALTO-IQ3-XXXXXX anpingen(XXXXXX entspricht den letzten 6 Ziffern der MAC).
- D** 1. L'appareil est configuré en utilisant Nebula App.
2. Test Ethernet: Sans aucun type de configuration, l'IQ3 est un appareil prêt pour le DHCP. Si votre réseau le supporte, il est possible de vérifier la connectivité Ethernet en envoyant une requête à l'adresse SALTO-IQ3-XXXXXX(XXXXXX correspond aux 6 derniers chiffres du MAC).
- P** 1. O dispositivo é configurado utilizando Nebula App.
2. Teste Ethernet: sem qualquer tipo de configuração, o IQ3 é um dispositivo pronto para DHCP. Se suportado pela sua rede, é possível verificar a ligação Ethernet através do endereço SALTO-IQ3-XXXXXX (XXXXXX corresponde aos dígitos finais do MAC).

Eng Installation example **E** Ejemplo de instalación **D** Installationsbeispiel **F** Exemple d'installation **P** Exemplo de instalação

- Eng** Maximun number of SALTO Nodes: 6
Maximun number of access points: 112
- E** Número máximo de SALTO Node: 6
Número máximo de puntos de acceso: 112
- D** Maximale Anzahl von SALTO Nodes: 6
Maximale Anzahl con Access Points: 112
- F** Nombre maximal de Nœuds SALTO: 6
Nombre maximal de points d'accès: 112
- P** Número máximo de Nodos SALTO: 6
Número máximo de pontos de acesso: 112

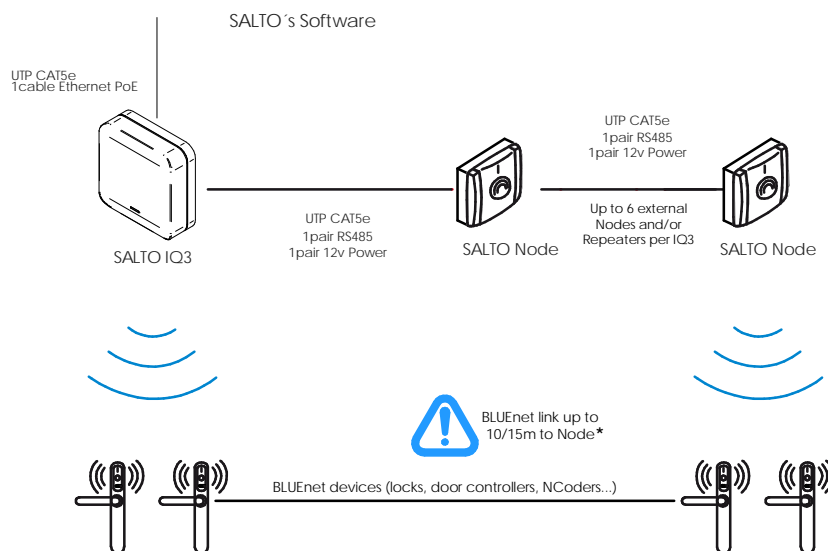







(*) Depending upon installed environment.

Installation guide

IQ3.0

SALTO
inspiredaccess

Eng Signals
 E Señalización
 D Signale
 F Signaux
 P Sinais

LED MODE MODO DE LED LED ANZEIGE MODE LED MODO DO LED	LED COLOUR COLOR DE LED FARBE COULEUR COR	STATUS INDICATION INDICACIÓN DE ESTADO STATUS ÉTAT ESTADO
Blink long RED Parpadeo largo- ROJO Blinken lange ROT Clignotement long ROUGE Piscar longo- VERMELHO		Device ex works. It will be doing advertising. Dispositivo en fábrica. Estará haciendo advertising. Gerät ab werk. Bereit zur Anmeldung. Le dispositif ex fonctionne. Il fera de la publicité. O dispositivo em ex-work. Ira iniciar o modo de publicidade.
Blink short RED (3 seconds) Parpadeo corto- ROJO (3 segundos) Blinken kurz ROT (3 seconds) Clignotement court ROUGE (3 secondes) Piscar curto- VERMELHO (3 segundos)		Identification signal when selected from a mobile phone. The signal lasts 3 second. Señal de identificación al seleccionarlo desde un móvil. La señal dura 3 segundos. Identifikationssignal bei Auswahl von einem Mobiltelefon. Das Signal dauert 3 Sekunden. Signal d'identification lors de la sélection à partir d'un téléphone mobile. Le signal dure 3 secondes. Sinal de identificação quando selecionado a partir de um telemóvel. O sinal tem a duração de 3 segundos.
Blink long BLUE Parpadeo largo- AZUL Blinken lange BLAU Clignotement long BLEU Piscar longo- AZUL		Device initialized with communication to the server. Dispositivo inicializado con comunicación al servidor. Gerät initialisiert und kommuniziert mit Server. Dispositif initialisé avec la communication au serveur. Dispositivo inicializado com comunicação para servidor.
Blink short YELLOW Parpadeo corto- AMARILLO Blinken kurz GELB Clignotement court JAUNE Piscar curto- AMARELO		Device not communicating with the server. Dispositivo sin comunicación con el servidor. Gerät kommuniziert nicht mit dem Server. Le dispositif ne communique pas a vec le serveur. Dispositivo não está a comunicar com o servidor.
Blink long GREEN Parpadeo largo- VERDE Blinken lange GRÜN Clignotement long VERT Piscar longo- VERDE		Connection established to a mobile phone. Conexión establecida a un móvil. Verbindung zu Mobiltelefon hergestellt. Connexion établie avec un téléphone portable. Ligação estabelecida a um telemóvel.
Blink short GREEN Parpadeo corto- VERDE Blinken kurz GRÜN Clignotement court VERT Piscar curto- VERDE		Initialized and in programing mode. It is doing advertising while waiting for a mobile connection. Inicializado y en modo programación. Está haciendo advertising a la espera de conexión de un móvil. Initialisiert und im Programmiermodus. Bereit zur Anmeldung während auf eine Verbindung zum Mobiltelefon gewartet wird. Initialisé et en mode de programmation. Il fait de la publicité tout en attendant une connexion mobile. Inicializado e em modo de programação. Está em modo de publicidade enquanto aguarda por uma ligação móvel.

Eng Operational test
 E Test operacional
 D Funktionsprüfung
 F Test opérationnel
 P Teste operacional

- Eng 1. Check that the red light turns on.
 2.If you have connected to Ethernet, check that the lights on the RJ45 turn on.
- E 1. Comprobar que se enciende la luz roja.
 2. Si ha conectado Ethernet, compruebe que se enciendan las luces del RJ45.
- D 1. Prüfen Sie, ob die rote LED leuchtet.
 2. Wenn Sie Ethernet angeschlossen haben, prüfen Sie, ob die LEDs am RJ45 aufleuchten.
- F 1. Vérifiez que le voyant rouge s'allume.
 2. Si vous avez connecté Ethernet, vérifiez que les laumieères sur le RJ45 s'allument.
- P 1. Verificar se a luz vermelha acende.
 2. Se tiver ligado o vabo ethernet , verifique se as luzes na RF47se acedem.